

8 7 6 5 4 3 2 1

REQ	ITEM	PART NUMBER	DESCRIPTION
1	1	24A3884	SHIELD WIRE MOUNT, LEFT
1	2	24A3832-1	SHIELD WIRE MOUNT INSULATING BOARD

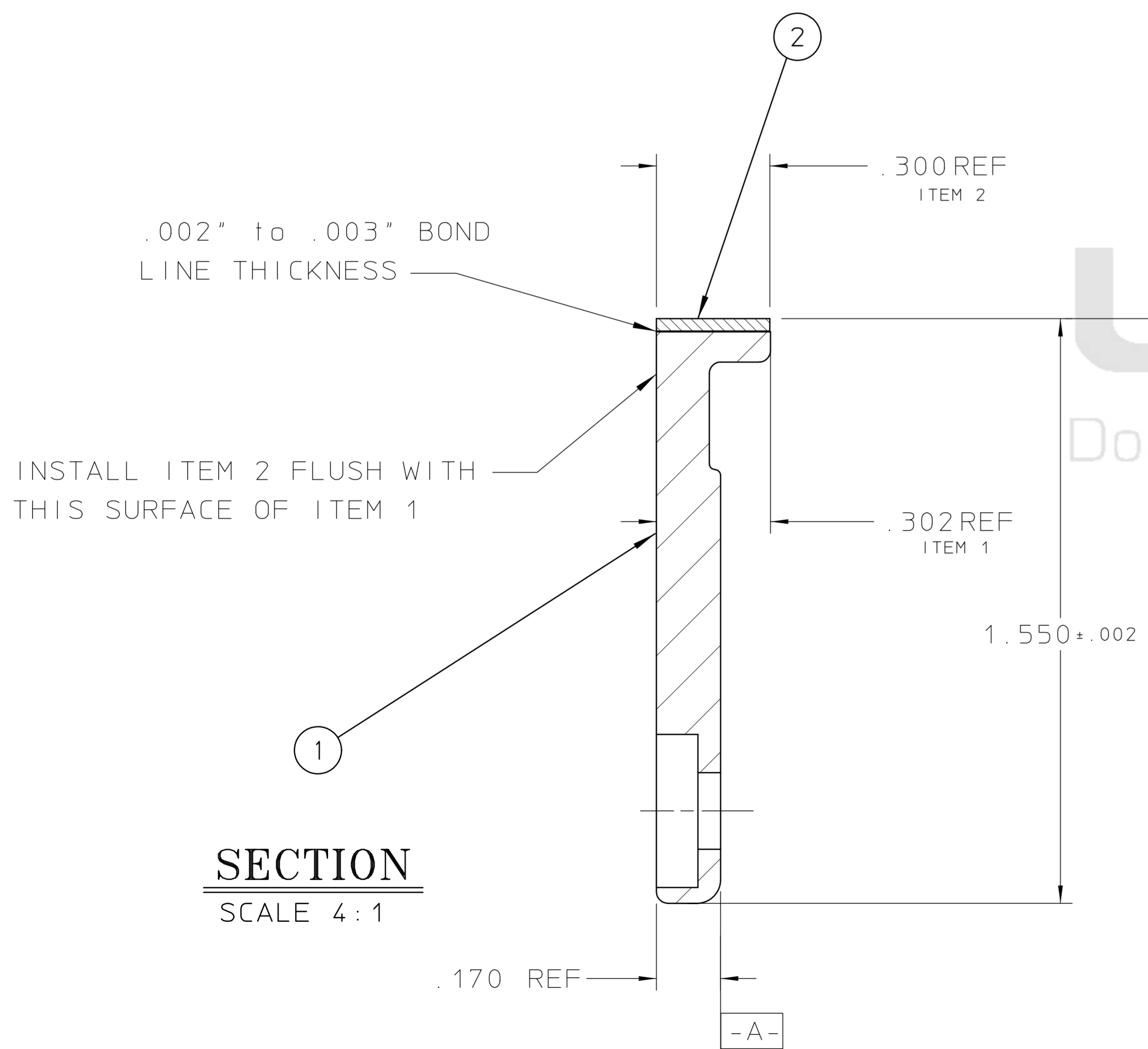
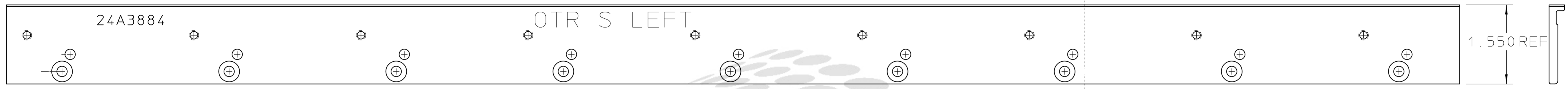
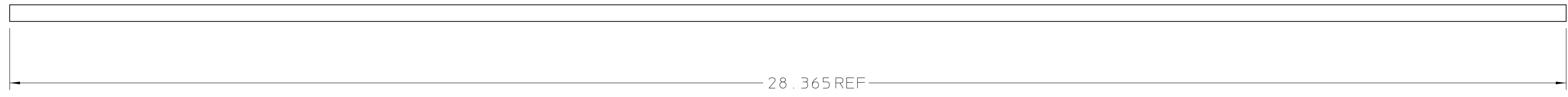

	.003	A
▧	.002	
RESTRAINED		

Document Control Center

24A4484

- NOTES
- CLEAN MATING SURFACES WITH ALCOHOL.
  - BOND ITEM 1 AND ITEM 2 TOGETHER WITH AN ADHESIVE MIXTURE OF 60% by weight "EPON 826" EPOXY RESIN TO 40% by weight "HENKEL VERSAMID 140". CURE AT 68°±5° F FOR 24 HRS.

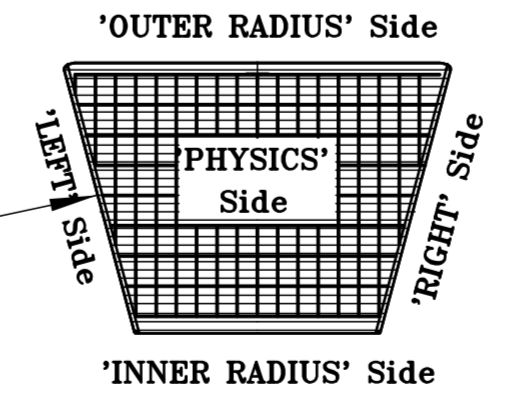

LOCATION of this PART in the OUTER SECTOR

SECTION  
SCALE 4:1

REV	DWG	CHK	ZONE	DATE	CHANGES	UNLESS OTHERWISE SPECIFIED			SHOP ORDERS			LAWRENCE BERKELEY LABORATORY UNIVERSITY OF CALIFORNIA-BERKELEY					
						TOLERANCES	.X ± .1	FRAC. ± 1/64	ACCT. NO.	SERIAL NO.	RHIC-STAR-TPC OUTER SECTOR						
							.XX ± .02	ANGLES ± 1°	DATE ISSD	DATE RECD.	NO. RECD.	SHIELD WIRE MOUNT ASSEMBLY, LEFT					
							.XXX ± .005	FINISH 125/7	DELIVER TO	SEE NOTE 1		PATENT CLEAR	DWG. TYPE	SHOWN ON	SCALE	FULL	DO NOT SCALE PRINTS
						THREADS ARE CLASS 2	CHAMFER ENDS OF ALL SCREW THREADS 30°			CUT 1.5 PITCH THRO RELIEF WITH ROUND NOSE TOOL ON MACHINE CUT THREADS.			DETAIL	00X0000	DWG. NO.	SIZE	REV.
						BREAK EDGES .016 MAX. ON MACHINED WORK	REMOVE BURRS WELD SPLATTER & LOOSE SCALE			DATE 94-04-22	DATE 94-04-22	MICROFILMED	DESIGN ACCT. NO. 8052-24	CATEGORY CODE SR-02-04	24A4484		
						REFERENCES: ANSI Y14.5 & B46.1.	SURFACE TREATMENT			TAG							
							IDENT. METH.			DATE 94-04-22							
							BY J. BOEHM			DATE 94-04-22							
							CHK J. BERCOVITZ			DATE 94-04-22							