

REQD	ITEM	PART NUMBER	DESCRIPTION
24A4252A			SILICON BRONZE TYPE CDA 647 or CDA 655

2 x CHAMFER TO MAJOR THREAD DIA

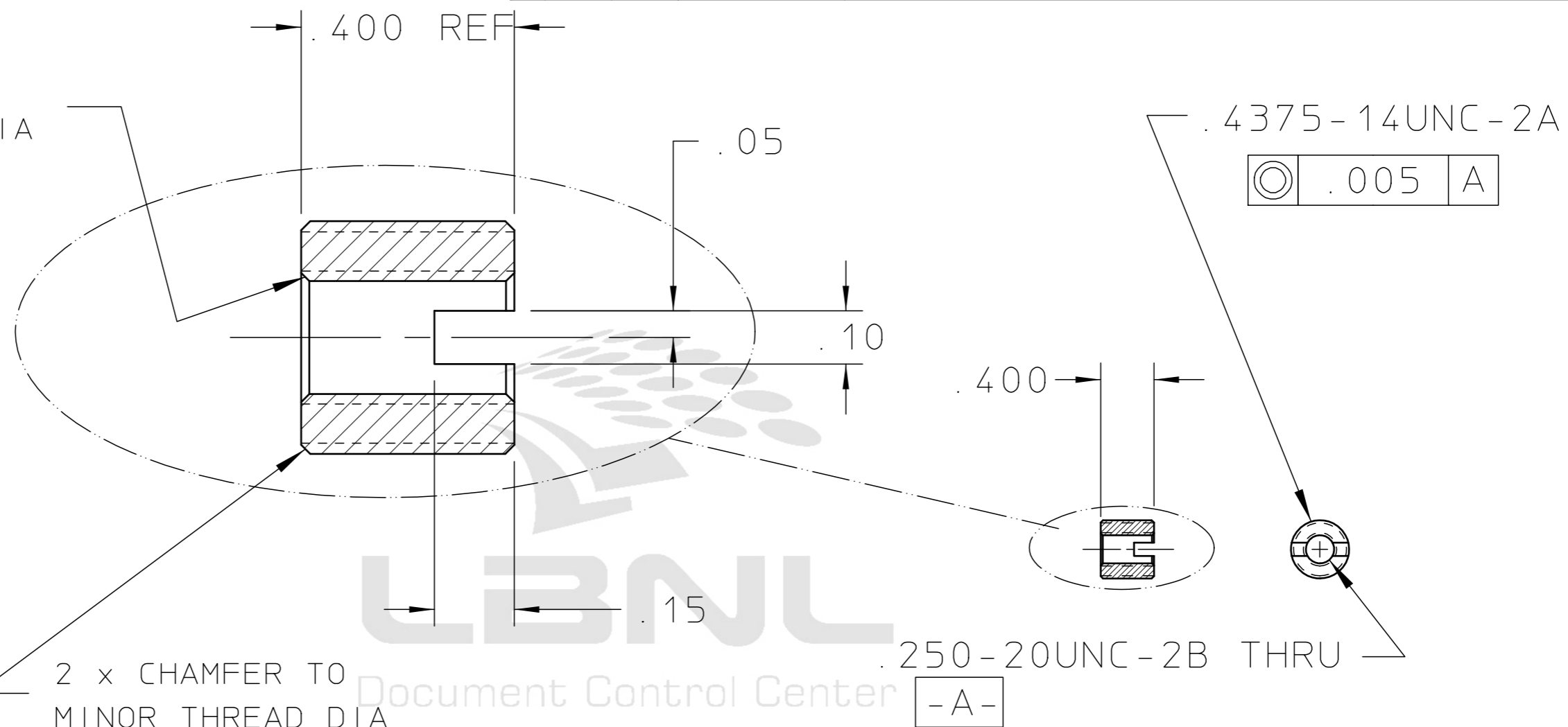

Detail
SCALE 4:1

2 x CHAMFER TO MINOR THREAD DIA

LBNL
Document Control Center

				UNLESS OTHERWISE SPECIFIED	SHOP ORDERS			LAWRENCE BERKELEY LABORATORY				
				TOLERANCE .X ± .1 .XX ± .02 .XXX ± .005	ACCT NO	SER NO		UNIVERSITY OF CALIFORNIA-BERKELEY				
				SURFACE FINISH 125 ✓	DATE ISSD	DATE REQD	NO REQD	RHIC-STAR-TPC				
				1. SAWED, FLAMECUT, SHEARED OR CUT STOCK FINISH. 2. THREADS CLASS 2. 3. CHAMFER ENDS OF ALL SCREW THRDS 30°. 1 1/2 PITCH RELIEF WITH ROUND NOSE TOOL ON ALL MACHINE CUT THRDS. 4. 1 1/2 PITCH RELIEF WITH ROUND NOSE TOOL ON ALL MACHINE CUT THRDS. 5. BREAK EDGES 1/64 MAX. ON MACHINE WORK. 6. REMOVE BURRS, LOOSE SCALE AND WELD SPLATTER. 7. REF.-USASI OR ASA STDS SECT Y-14 & B46-1.	DELIVER TO			OUTER AND INNER SECTOR				
					SURFACE TREATMENT			WIRE MOUNT THREAD SUPPORT .25-20				
					IDENTIFIC BAG & TAG METHOD			PAT CLEAR	DWG TYPE	SHOWN ON	SCALE: FULL	
					DWG BY J. BOEHM			DATE 94-03-17	DETAIL	24A0000	DO NOT SCALE PRINTS	
REV	DWN	CHK	DATE	DESCRIPTION	CHK BY J. BERCOVITZ	DATE 94-03-17	MICROFILMED	DESIGN ACCT NO 8052-24	CATEGORY CODE SR-02-04	DWG NO 24A4252A	REV	

Officially Released to the LBNL Document Control Center
Released: DCC Auth Key: X14P42U4W0