

REQ	ITEM	PART NUMBER	DESCRIPTION
STEEL	TOOL	FLAT	PRECISION GROUND, .500 THICK, QQ-T-570, CLASS 01

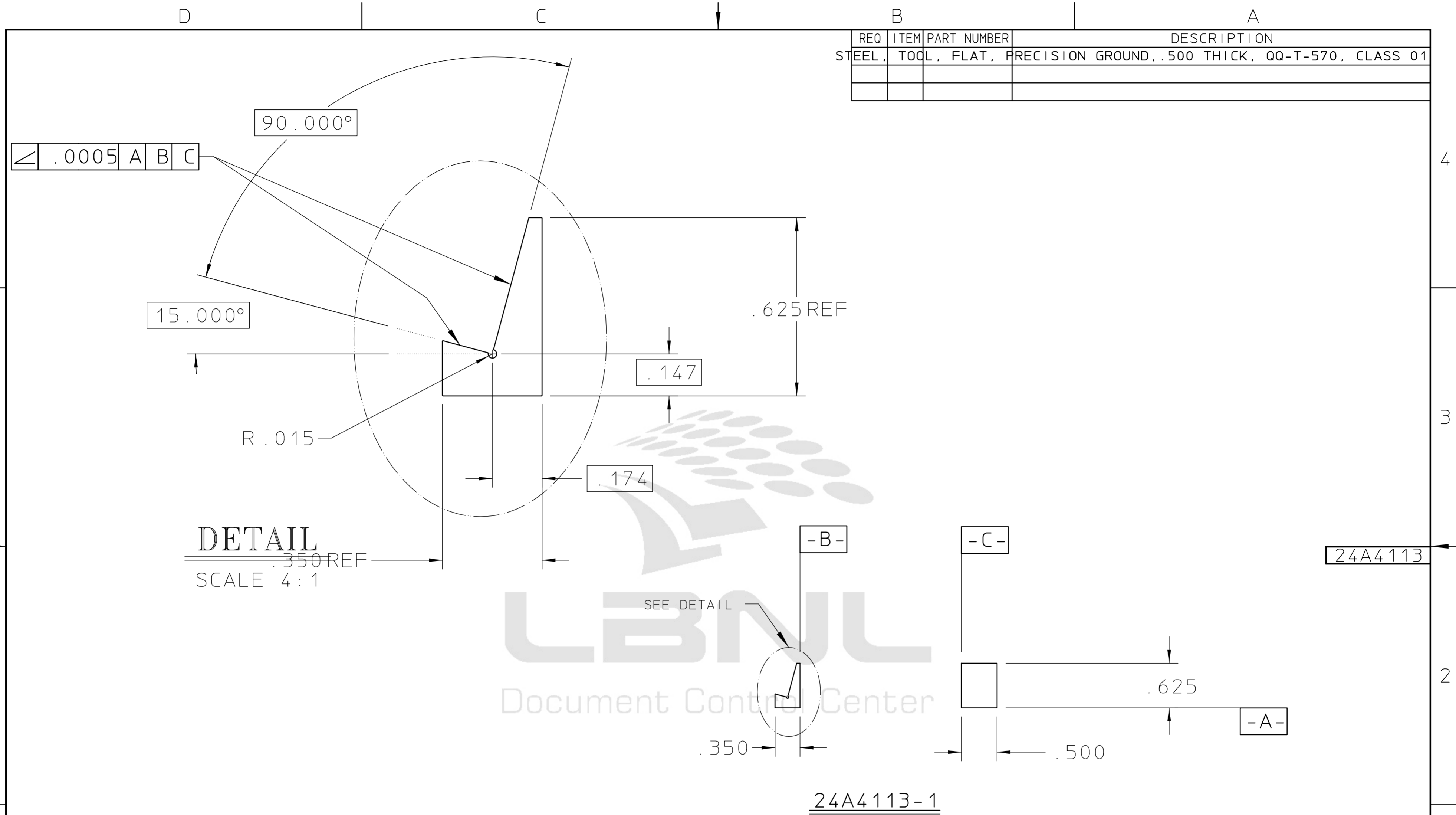

REV	DWG	CHK	ZONE	DATE	CHANGES	UNLESS OTHERWISE SPECIFIED		SHOP ORDERS			LAWRENCE BERKELEY LABORATORY							
						TOLERANCES	.X ± .1	FRAC. ± 1/64	ACCT. NO.	SERIAL NO.	UNIVERSITY OF CALIFORNIA-BERKELEY							
							.XX ± .02	ANGLES ± .01°	DATE ISSD	DATE REQD.	NO. REQD.	RHIC-STAR-TPC						
							.XXX ± .005	FINISH 125√	DELIVER TO	DEGREASE			COOLING TUBE INSPECTION					
						THREADS ARE CLASS 2 CHAMFER ENDS OF ALL SCREW THREADS 30° CUT 1.5 PITCH THRO RELIEF WITH ROUND NOSE TOOL ON MACHINE CUT THREADS.			SURFACE TREATMENT			INSPECTION TOOL						
						BREAK EDGES .016 MAX. ON MACHINED WORK REMOVE BURRS WELD SPLATTER & LOOSE SCALE REFERENCES: ANSI Y14.5 & B46.1.			IDENT. METH.	TAG		PATENT CLEAR	DWG. TYPE	SHOWN ON	SCALE	FULL	DO NOT SCALE PRINTS	
									DWG. BY	J. BOEHM	DATE	94-03-04	MICROFILMED	DESIGN ACCT. NO.	CATEGORY CODE	DWG. NO.	SIZE	REV.
									CHK. BY	J. BERCOVITZ	DATE	94-03-04		8052-24	SR0204	24A4113		