

DETAIL "A"  
SCALE: HALF SIZE

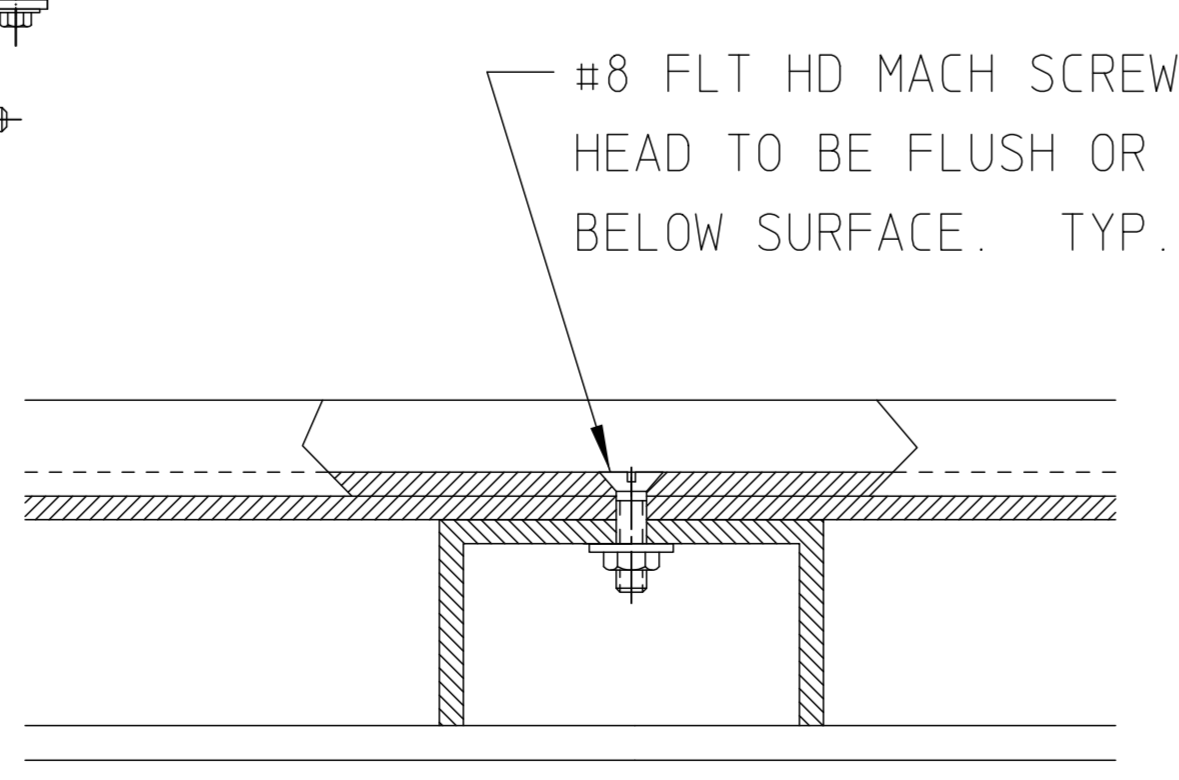
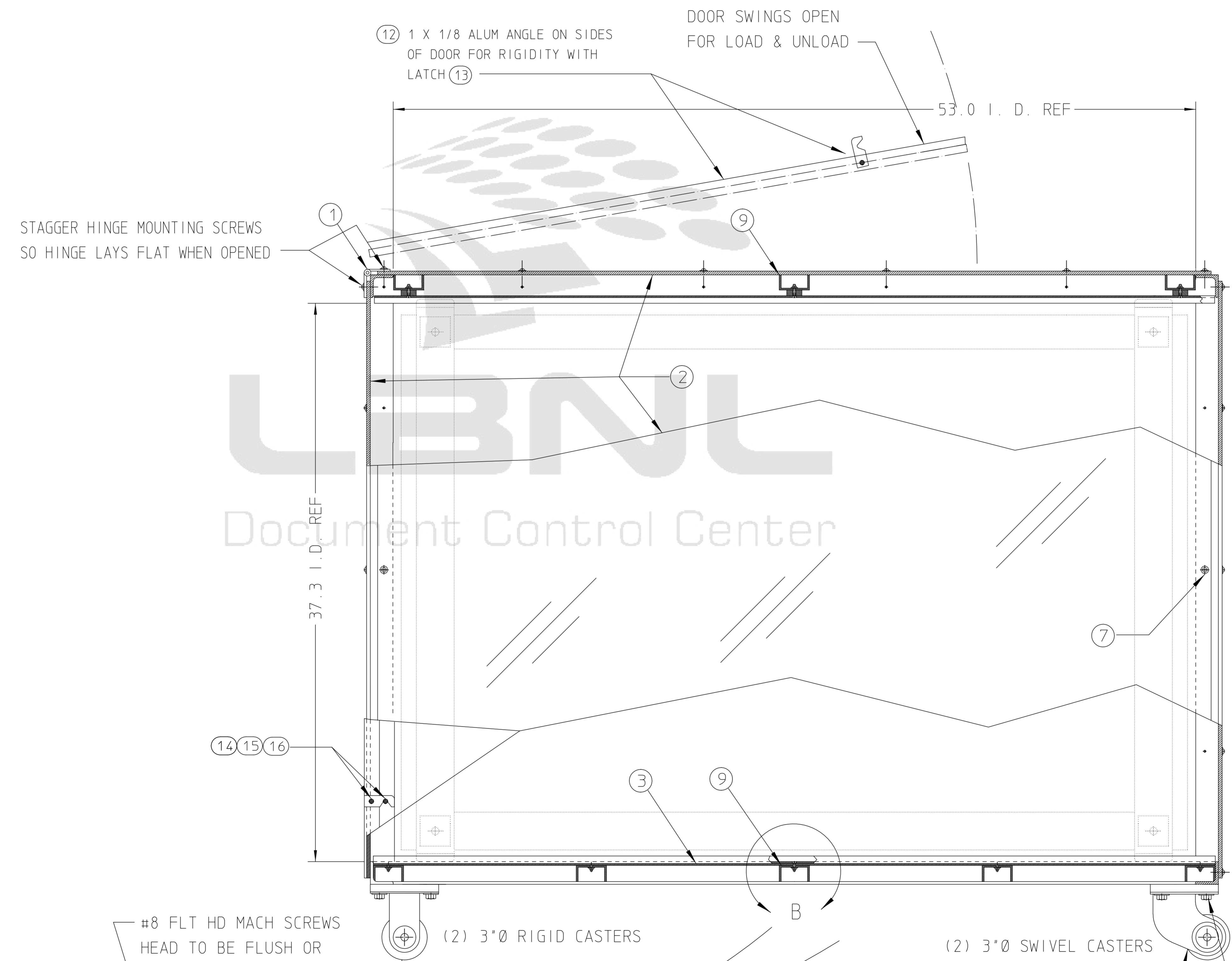
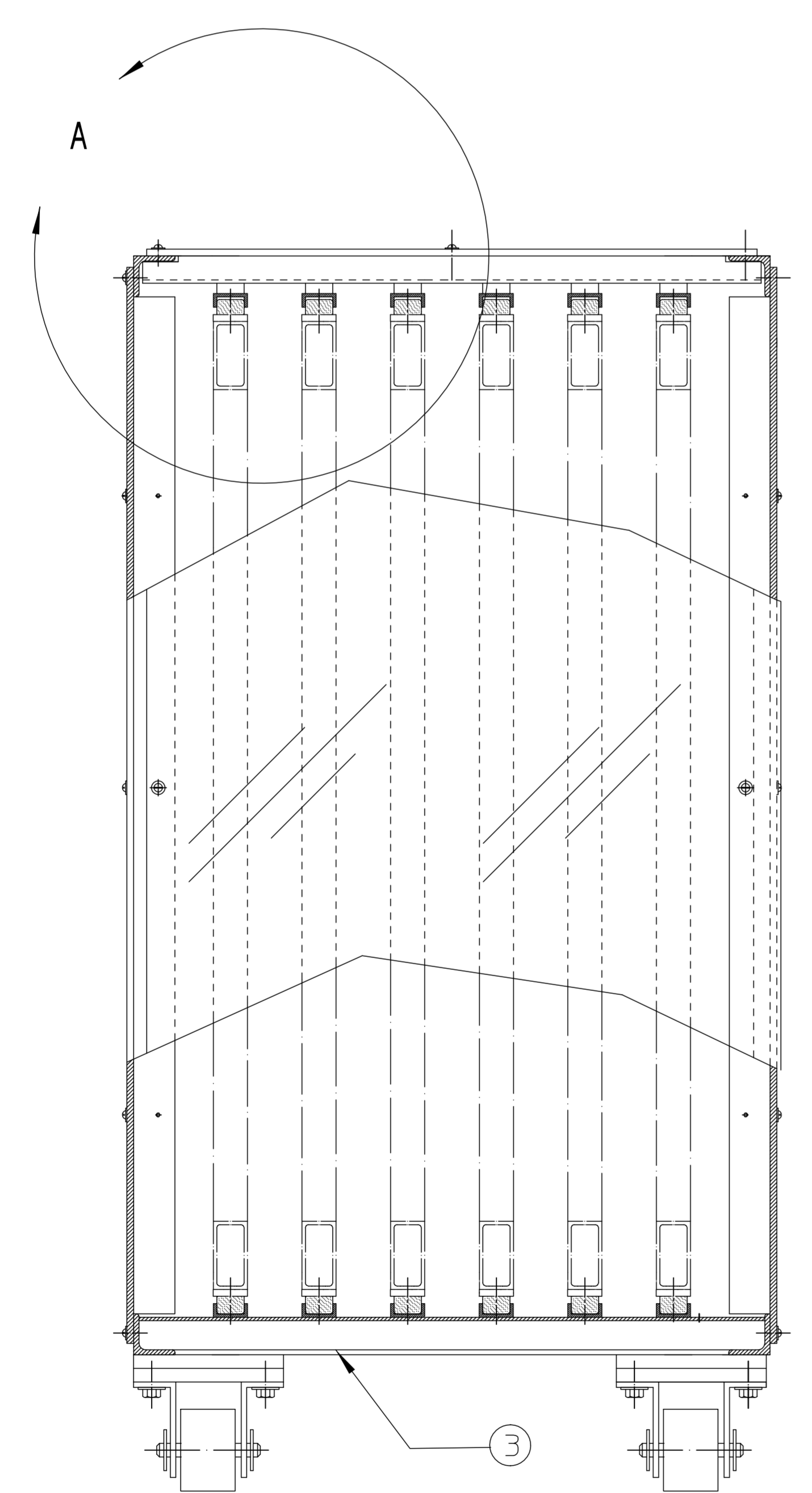
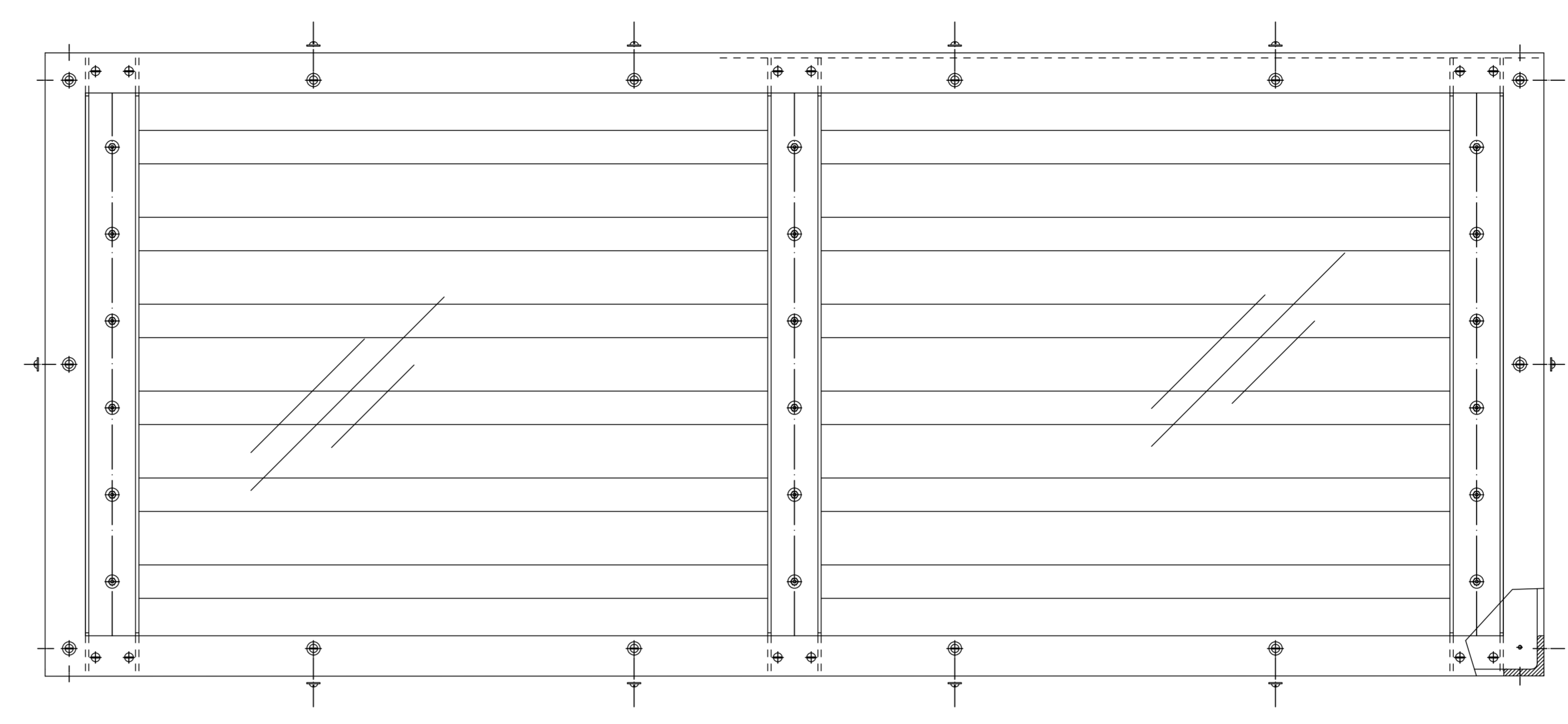

DETAIL "B"  
TRACK HOLD-DOWN  
SCALE: FULL SIZE

REV	DATE	DESCRIPTION
4	16	LOCK NUT 10-24UNC HEX STL
2	15	CAP SCREW, SOC HD 10-24UNC X 1.00LG STL
2	14	CAP SCREW, SOC HD 10-24UNC X 0.25LG STL
2	13	SHEET DELRIN .5 X.75 X 2.0
2	12	ANGLE, ALUMINUM ALLOY 6061-T6 X 1 X 1/8"
18	11	PLATE, ALUMINUM ALLOY 6061-T6 X 1' SQUARE X 3/8 THK
12	10	CHANNEL ALUMINUM ALLOY 6061-T6 X 1.25" X 0.5" X 1/8 THK
8	9	CHANNEL ALUMINUM ALLOY 6061-T6 X 2" X 1" X 1/8 THK
16	8	WASHER, 3/8 NOM STL
AR	7	SHT METAL SCREW, NO 10 X 1/2 LG STL SELF TAPPING
16	6	CAP SCREW, HEX HD, 3/8-16UNC X .5 LG STL
2	5	CASTER, COLSON SERIES 3 3" DIA RIGID OR EQUAL
2	4	CASTER, COLSON SERIES 3 3" DIA SWIVEL OR EQUAL
1	3	SHEET, ALUMINUM ALLOY 6061-T6 X 1/8 THK
AR	2	SHEET, PLEXIGLASS X 1/4" THK, CLEAR
AR	1	HINGE, 1.5 X 1.5 BUTT, CONTINUOUS
1		24A0683 STORAGE CART FRAME

REV	DWG	CHK	ZONE	DATE	CHANGES

CO	XX	FRAC	ANGLES	FINISH	THREADS	CHAMFER	RELIEF	BREAK	REMOVE	REFERENCES
X	± 1	FRAC ± 1/64	± 1°	125/7	CLASS 2	30°	3/16"	0.06 MAX	WELD	ANSI 114.3 & B46.1

ACCY	SERIAL	DATE	DATE	DATE	DATE

CLIENT	DWG. TYPE	SHOW ON	SCALE	DO NOT SCALE
R. CAYLOR	ASSEMBLY		1:4	

PATENT CLEAR	DESIGN ACT. NO.	CATEGORY CODE	DWG. NO.	SIZE	REV.
	8052-24	SR-04-02	24A0696		