

REQ	ITEM	PART NUMBER	DESCRIPTION
			COLD ROLLED STEEL

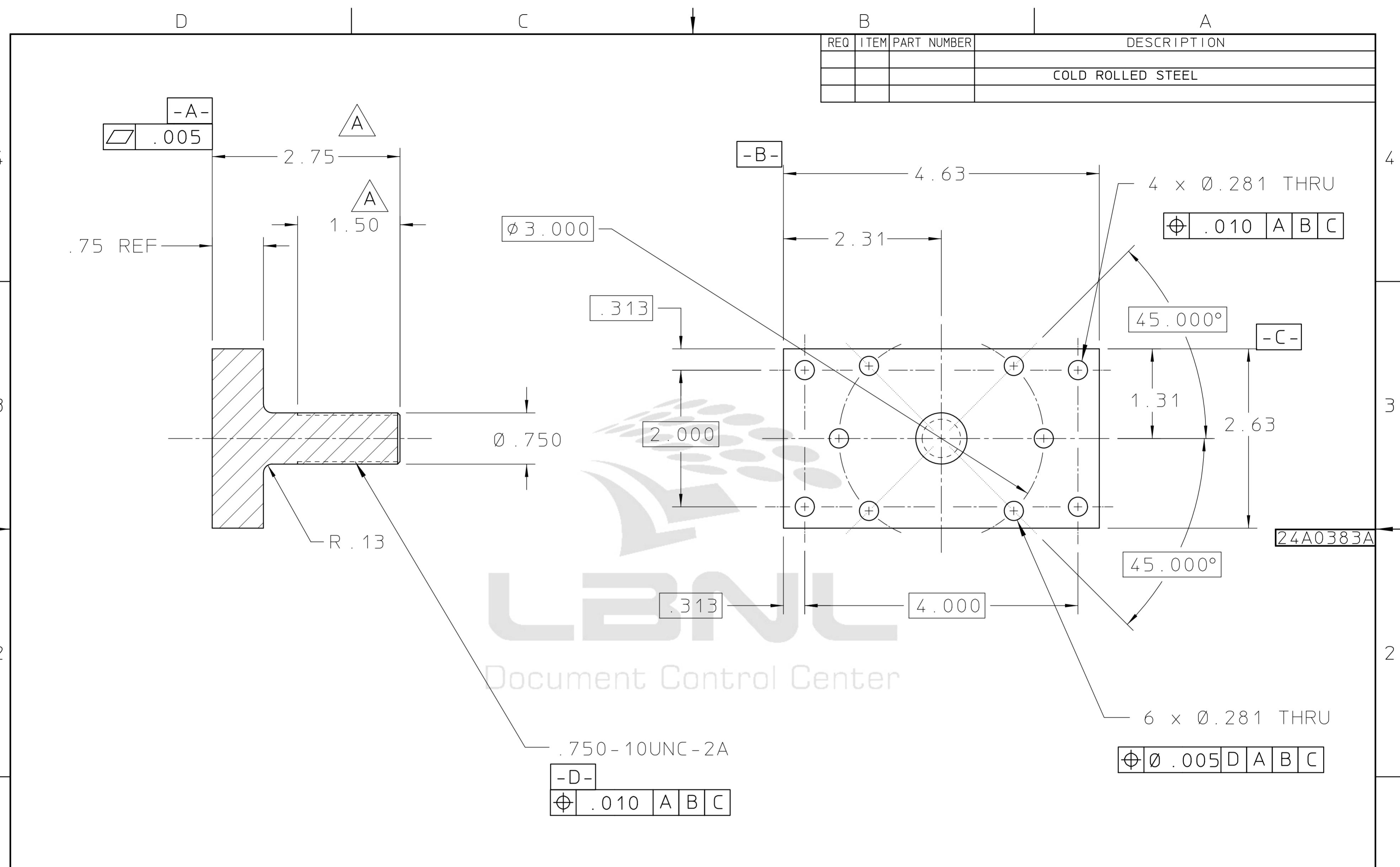

24A0383A

UNLESS OTHERWISE SPECIFIED					SHOP ORDERS			LAWRENCE BERKELEY LABORATORY				
TOLERANCES	.X ± .1	FRAC. ± 1/64	ACCT. NO.	SERIAL NO.	UNIVERSITY OF CALIFORNIA-BERKELEY							
	.XX ± .02	ANGLES ± .01°	DATE ISSD	DATE RECD.	RHIC-STAR-TPC							
	.XXX ± .005	FINISH 125√	DELIVER TO		SECTOR HANDLING FIXTURE							
	THREADS ARE CLASS 2		SURFACE TREATMENT BLACK CARBURIZE		TRUNNION SHAFT							
	CHAMFER ENDS OF ALL SCREW THREADS 30°		IDENT. METH. STL STMP ± HIGH		PATENT CLEAR	DWG. TYPE	SHOWN ON	SCALE	FULL	DO NOT SCALE PRINTS		
	CUT 1.5 PITCH THRU RELIEF WITH ROUND NOSE TOOL ON MACHINE CUT THREADS.		DWG. BY J. BOEHM		DATE 93-03-16	ASSEMBLY	24A0354	DWG. NO.	24A0383	SIZE	REV.	
	BREAK EDGES .016 MAX. ON MACHINED WORK		CHK. BY J. BERCOVITZ		DATE 93-03-16	DESIGN ACCT. NO.	8052-24	CATEGORY CODE	SR-02-04			
	REMOVE BURRS WELD SPLATTER & LOOSE SCALE											
	REFERENCES: ANSI Y14.5 & B46.1.											
REV	DWG	CHK	ZONE	DATE	CHANGES							

Officially Released to the LBNL Document Control Center
Released: DCC Auth Key: 6FEMORDY2B
Downloaded by: James H Thomas at August 12, 2014 12:52:41