

ANALOG AUXILIARY INTERFACE

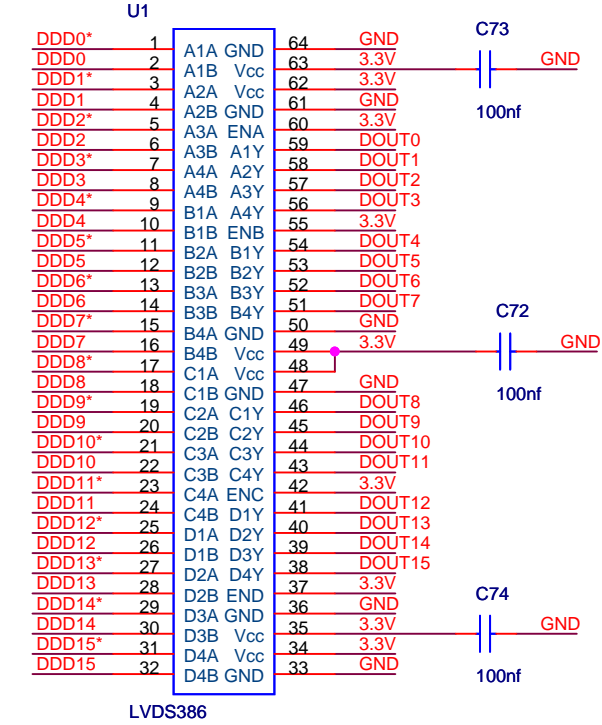

Mimostar-3 additions

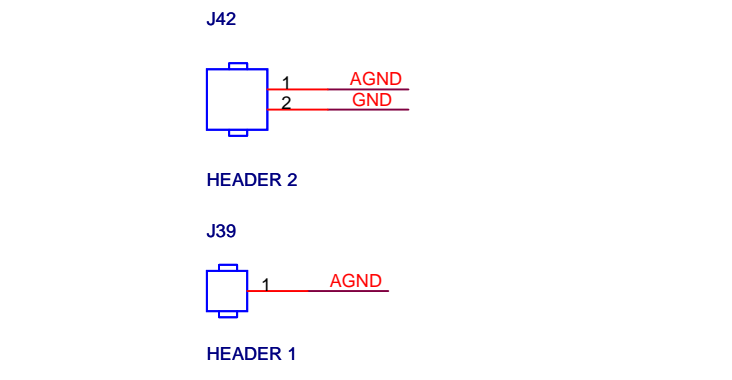
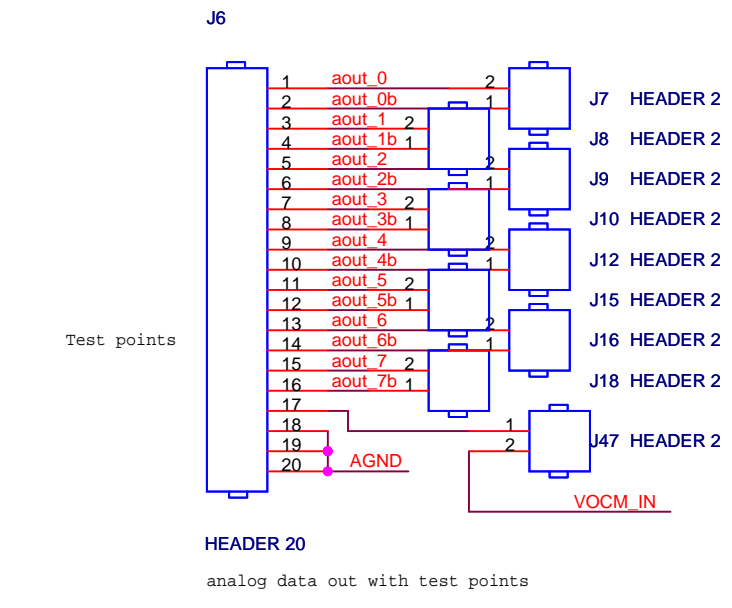
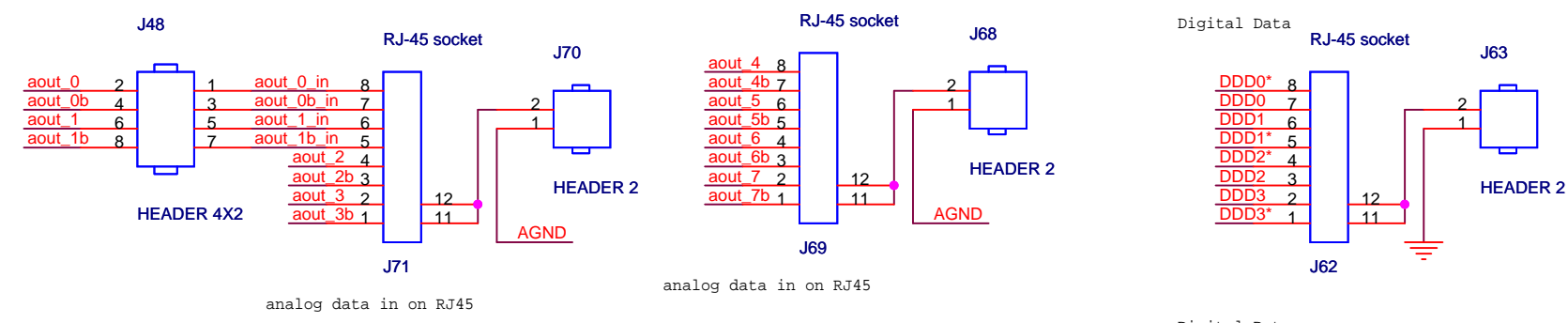
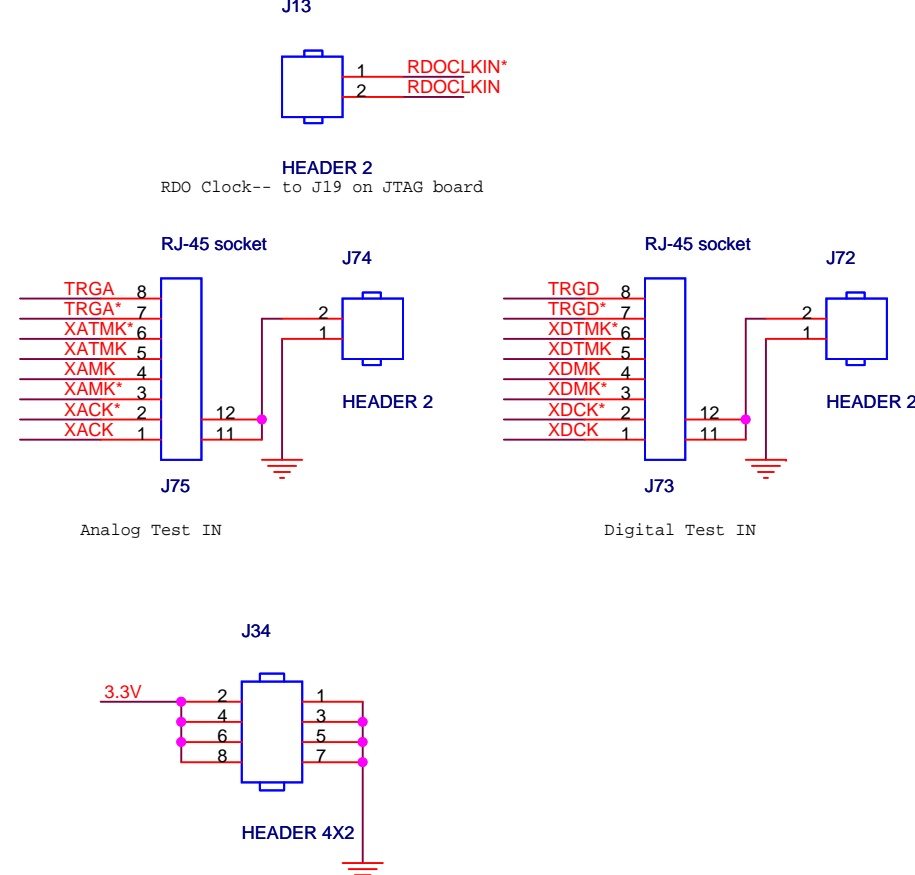
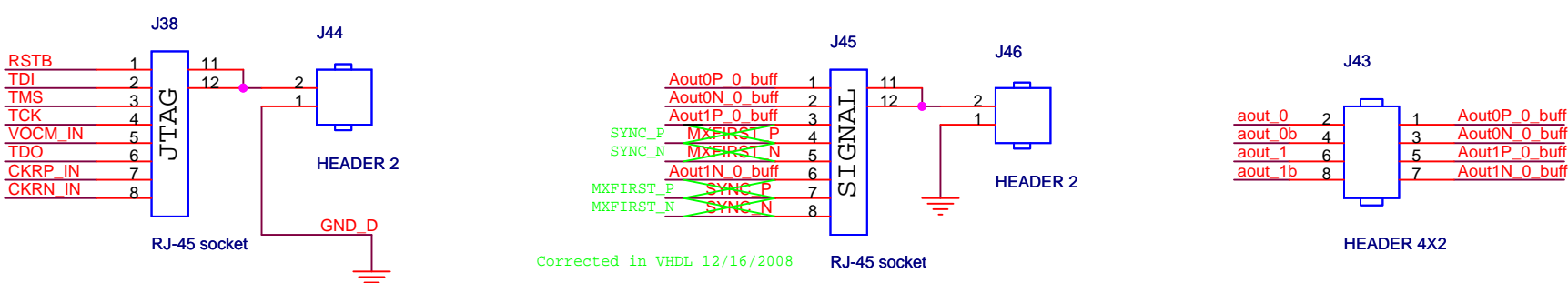

DIGITAL AUXILIARY INTERFACE

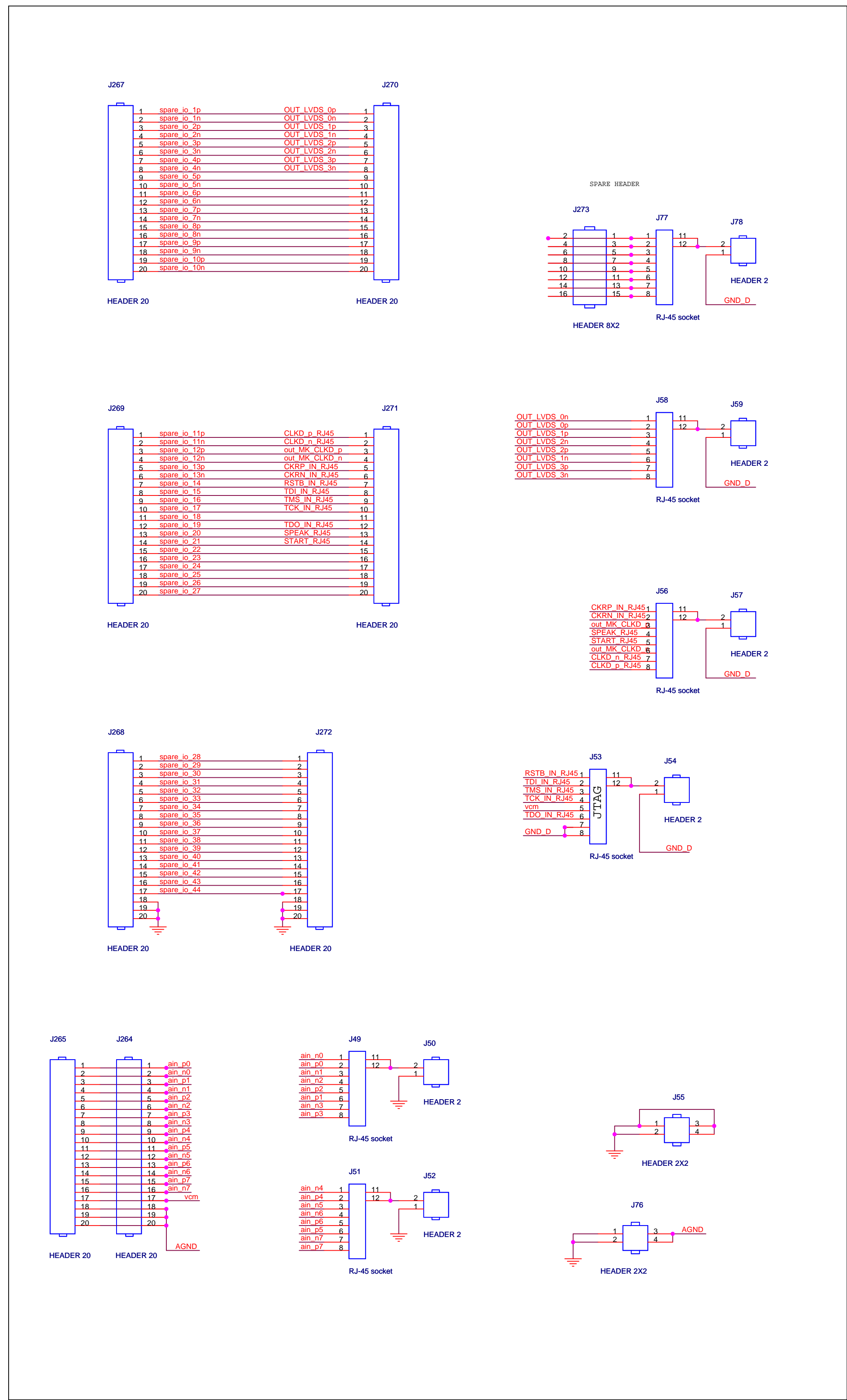
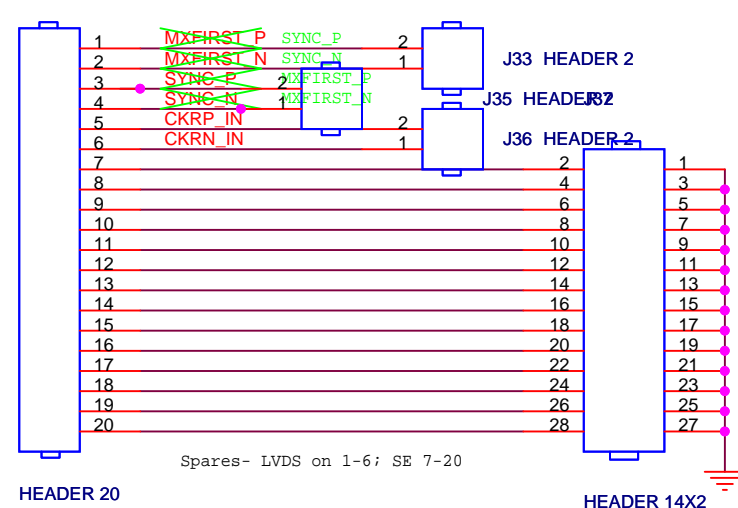
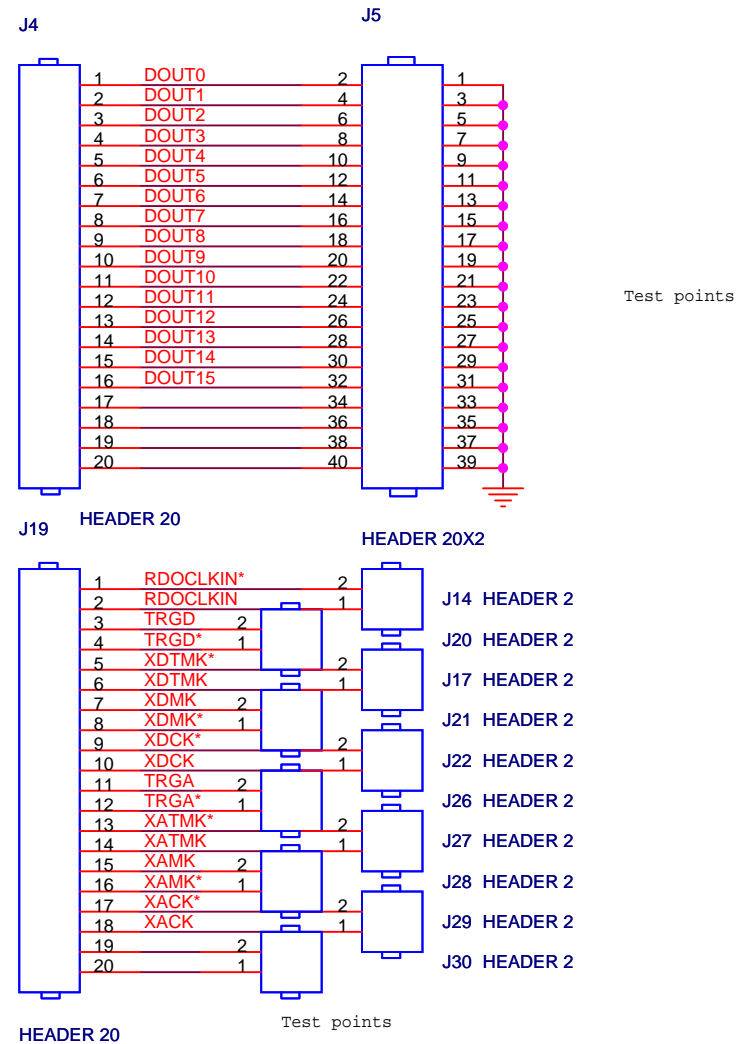

Mimosa-22 and Mimostar-3 interface Board

Phase-1 Interface Board

File	Mimisa-22, Mimostar-3, Phase-1 Interface board	Rev	<Rev>
Size	Document Number	Date	Tuesday, December 16, 2008
D	<Doc>	Sheet	1 of 1